

AS 90

- Buckets : 700 to 1200 litres
- Engine power : 70 HP
- Hydrostatic transmission
- Monobloc chassis / swinging arm
- 4-wheel-steering
- Automatic locking of the rear axle oscillation
- Hydraulic attachment quick-coupling device
- Hydraulically assisted joystick

Swinging arm 180°



MANITOU LOADER

MANI LOADER

ENGINE

Oil/air -cooled DEUTZ Diesel Engine,
4 cylinders turbo, 4-stroke, direct injection

Type	BF 4L	1011F
Power at 2,500 rpm according to ISO 9249	51,5 (70 HP)	kW
Max. torque at 1,650 rpm according to ISO 9249	220	Nm
Fuel consumption at max. torque	222	g/kWh
	163	g/HPH

Air filter aspiration 2 levels (safety cartridge)

Electrics :		
Voltage	12	V
Battery	88	Ah
Alternator output	840 W	60 AT
Starter	(3 HP)	2,2 kW

TRANSMISSION

Load-adjusting hydrostatic transmission with two gears giving maximum pushing force, switchable while under load - 4-wheel drive 4-wheel steering.

Multifunction joystick and forward/reverse lever.

Axes :		planetary axles
Steering :		4-wheel steering
Oscillation :		on rear axle
Differential :	limited slip differential in the front axle	
Limited slip differential front :		45%

Tyres :	Standard	365/80 R20
	Option	405/70 R20

Travel speed :	Standard	0-20 km/h
	Option	0-38 km/h

Working speed :		0-6 km/h
-----------------	--	----------

Gradeability :		60%
Ground clearance at differential :		370 mm
Ground clearance centre of vehicle :		465 mm

DESIGN

- Chassis :**
- Rigid chassis concept (stability guaranteed) in high-quality steel, welded.
 - Automatic blocking of the rear axle oscillation from 30° of rotation of the arm.
 - Constant speed of rotation of the arm
 - Crown-wheel with internal cogs
 - "Z" bar linkage : 100% parallel lift.
 - Automatic return of the bucket to working position

Cab : comfortable, fully suspended (mounted on 4 silent-blocs)

Standard machine	
Noise level cab (dynam.) :	78 dB (AT)
Sound level ext. max. (dynam.) :	97 dB (AT)

STEERING

Oscillation angle	2 x 10°
Steering angle	33°

Outside turning radius	R = 3660 mm
------------------------	-------------

BRAKING SYSTEM

Service brake : multi-disc brake (oil immersed), operated hydraulically on the front axle and acting on all 4 wheels by the transmission

"Inching" function on service brake

Parking brake : mechanically-controlled brake acting on the front axle.

HYDRAULICS

Double hydraulic system :

First circuit : Lifting / lowering / crowding / dumping / attachment controls ; and steering (via priority valve) ; 4-way hydraulic distributor with pressure controls on outlets.

Hydraulically-assisted steering and joystick controls / proportional controls.

Flow and pressure max.
At 2,500 rpm : 82,5 l /min & 200 bar

2nd circuit : swinging controls; single hydraulic distributor with pressure controls on outlets.

Flow and pressure max.
At 2,500 rpm : 35 l /min & 200 bar

Floating position on loader arm.

Cylinders :	2 lift cylinders	ø 90 mm
	1 tilt cylinder	ø 100 mm
	2 swinging cylinders	ø 100 mm

Cycle times according to DIN ISO 7131 :	
Lifting (with load)	5,8 s
Lowering (without load)	3,5 s
Dumping 90°	2,0 s
Crowding 45°	1,5 s
Swinging 90°	3,5 s

FILLING CAPACITIES

Fuel tank	75 l
Hydraulic circuit including tank	130 l

PERFORMANCE

Digging depth (standard bucket)	95 mm
---------------------------------	-------

Crowding angle	44°
Dumping high	45°
Dumping max. (AAL)	105°

AS 90

AS 90

DIAGRAMS

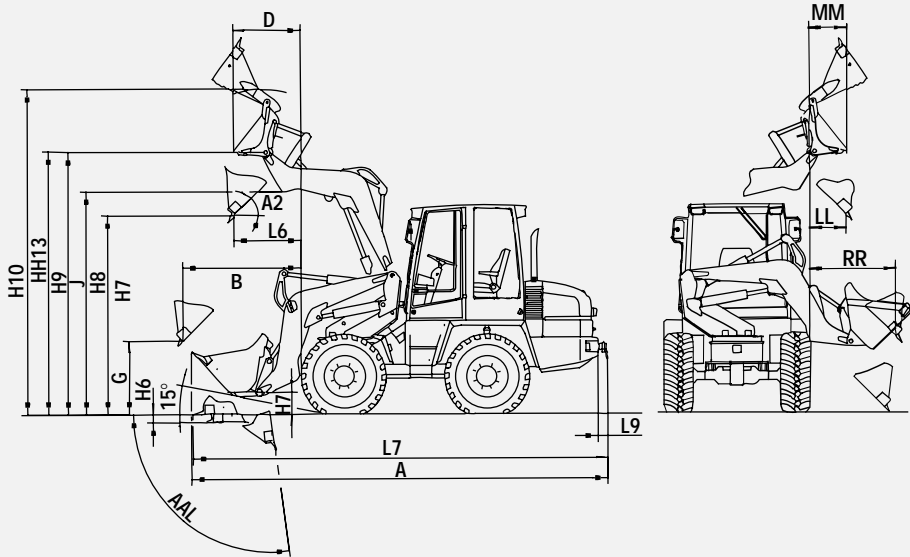

	Standard	Multipurpose
Volume :	0,9 m ³	0,8 m ³
A	5695	5665
B	1415	1500
G	1050	970
H6	95	70
H7	550	430
H8	2650	2610
H9	3500	3500
H10	4370	4180
J	2940	2940
L6	780	860
L7	5530	5640
L9	125	125
D (open) :		900
HH13 (open) :		3470
LL	300	380
MM (open) :		420
RR	980	1050

Dimensions of machine	Dimensions in mm
	AS 90
Height	2720
Width over tyres	2030
Width over standard bucket	2100
Wheelbase	1900
Length with standard bucket	5695

TECHNICAL CHARACTERISTICS

CHARACTERISTICS WITH 365/80 R20 TYRES		STANDARD BUCKET		MULTIPURPOSE BUCKET	LIGHT-DUTY BUCKET
Volume according to DIN ISO 7546	m ³	0,9	0,7	0,8	1,2
Density according to ISO 8313	t/ m ³	1,7	2,0	1,8	1,15
Tipping load at max. reach in line acc. to ISO 8313	kg	3020	3140	2820	2880
Tipping load at max. reach, swung, acc. to ISO 8313	kg	2960	3140	2760	2800
Lifting force according to ISO 8313	daN	4000	4000	4000	4000
Tractive force	kN	42,8	42,8	42,8	42,8
Breakout force according to ISO 8313	daN	4550	4550	4350	4250
Width of the bucket	mm	2100	1950	2100	2000
Outside turning radius	mm	3660	3660	3660	3660
Dumping height under bucket	mm	2650	2710	2610	2500
Reach at max. height	mm	780	790	860	900
Maximum reach	mm	1415	1440	1500	1645
Permitted load - front axle	kg	4500	4500	4500	4500
Permitted load - rear axle	kg	4500	4500	4500	4500
Crowding angle	°	44	44	44	44
Dumping angle at max. height (A2)	°	45	45	45	45
Operating weight with bucket	kg	6130	6110	6345	6220

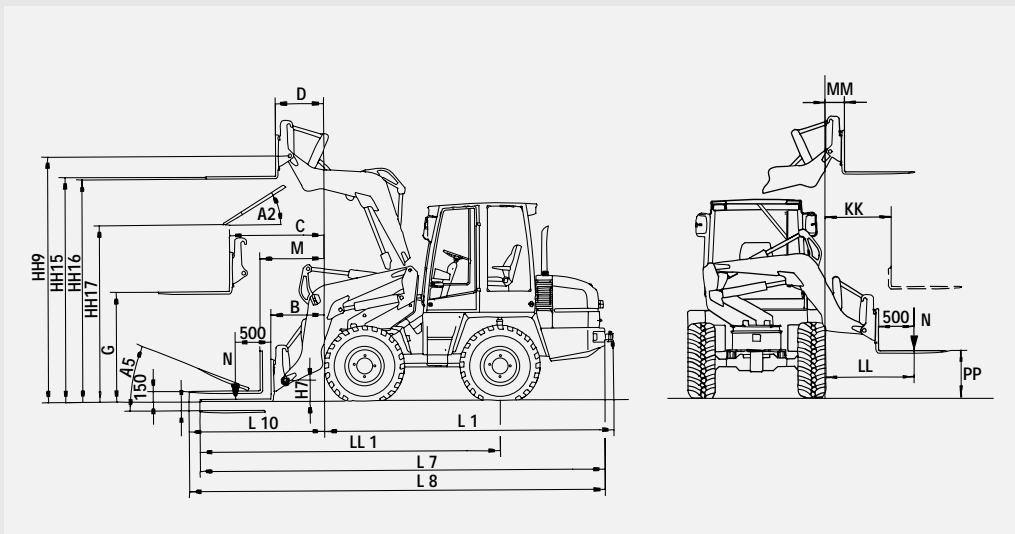

	AS 90
A2	28°
A5	20°
B	900
C	1350
D	660
G	1400
H6	170
H7	530
H9	3500
HH15	3050
HH16	3005
HH17	2460
LL1	4440
L1	4060
L7	5930
L8	6000
L10	2065
M	980
KK	900
LL	1240
MM	245
PP	600

		AS 90
Payload on pallet forks according to ISO 8313 (in front position)	Level ground	2315 kg
	Uneven ground	1600kg
Payload on pallet forks according to ISO 8313 (in swung position)**	Level ground	1965 kg
	Uneven ground	1470 kg
Payload on pallet forks according to ISO 8313 (in front position)*	Level ground	2550 kg
	Uneven ground	1910 kg

* forks 150 mm from ground level
 ** with handling kit

STANDARD EQUIPMENT

Comfortable 2-door ROPS cab - Seat with hydraulic suspension and weight adjustment - Adjustable steering column - Tinted windows - Windscreen wiper / washer front and rear - Sun visor - Sun roof - Heater rear window - Cut-off switch in the cab - Joysticks and lever for hydraulic attachments - Modular dashboard - Floating position on loader arm - Loader arm suspension - Warning display lights - Safety belt - Storage rack - Interior light 3-position heater/air conditioning (exterior air filter) - Mug holder - Radio installation facility - 1 interior rear mirror + 2 exterior - Electrical socket 12V in the cab - 2 driving lights mounted at the front and 2 working lights mounted at the rear of the cab - 2 working lights on the arm - Rotating beacon - Reversing lights, indicators and stop lights - Reverse alarm - Tool kit - Auxiliary hydraulic circuit - Bucket position indicator - Hydraulic attachment locking system - Towing facility.

LIST OF OPTIONS

38 k.p.h. Version -405/70 R20 Tyres - Radio - Anti-theft system (transponder or digicode) - Direct return line - Safety valves on lifting and crowding cylinders - Permanent power to the attachment circuit for road sweeper.

ATTACHMENTS

- Bucket
- Multipurpose bucket
- Grab fork
- Lifting jib
- Road sweeper
- Hydraulic hammer
- Forks
- etc. ...



This publication in no way constitutes an offer and the company reserves the right to alter specification without prior notice.
 The MANITOU models presented in this brochure can be supplied complete with optional equipment attachments



MANITOU B.F. S.A.
 B.P. 249 - 44158 ANCENIS CEDEX - FRANCE
 TEL : 33 2 40 09 10 11
 EXPORT DEPARTMENT FAX : 33 2 40 09 10 97
 www.manitou.fr