

# AS 200

- Standard bucket : 2 m<sup>3</sup>
- Engine : 171 HP
- Hydrostatic transmission

*Swinging system 180°*



**MANITOU** LOADER



# MANI LOADER

# AS 200

## ENGINE

Liquid - cooled Perkins Diesel engine  
6 Cylinder Turbo  
4-Stroke, direct injection

Type	F 1006-6 TW
Net output at according to ISO 9249 (171 HP)	2200 rpm 126 kW
Spec. fuel consumption at max. torque:	205 g/kWh 151 g/hph

Air filter: 2-phase dry type with safety cartridge

Electric system:

Voltage:	24	V
Battery:	110	Ah
Starter:	(5.4 hp)	4 kW

## TRANSMISSION

2-gear hydrostatic drive,  
Max. pushing force in both gears (can be switched under load). Joystick-operation of both drive system and working hydraulics.

Axles: planetary axles  
Steering and oscillating thanks to the articulated frame  
Differential : limited slip

locking value 45%  
in front and rear axles

Tyres: standard 20.5-25 16 PR  
option 20.5 R 25

Travel speed: standard: 0-20 km/h  
option 0-40 km/h

Working speed: 0- 9 km/h  
Gradeability: with payload 65%

Oscillation angle at the rear axle = +/- 11°  
Ground clearance at differential 500 mm

## BRAKE SYSTEM

Service brake :  
Wet multi-disc brakes, hydraulically activated,  
on front axle.

Parking brake :  
Spring-loaded brake on drive system

## STEERING SYSTEM

Hydrostatic rear axle steering  
Turning radius outside R = 6950 mm

## HYDRAULIC SYSTEM

Twin-circuit system with gear pumps

1. Working hydraulics' circuit (lifting/lowering, tilting, attachments) as well as steering (via priority valve) ; triple control valve.

Max. output at 2500 RPM : 100 l/min & 210 bar

2. Swing function circuit. Single control valve.

Max. output at 2500 RPM : 64 l/min & 180 bar

Operation cycles :	lifting (loaded)	6.5 s
	lowering (no load)	3.8 s
	crowding	1.1 s
	dumping	1.4 s
	swinging (90°)	3.8 s

## PERFORMANCE

Digging depth (standard bucket) : 65 mm  
Bucket angle : crowding 45°  
dumping at max. height 60°

Lift force : 10280 daN

Breakout force : 9500 daN

Pushing force : 11500 daN

Tipping load (with standard bucket) frontal 7740 kg  
articulated 7560 kg

Payload, pallet forks, (even terrain) frontal 4060 kg  
articulated 3550 kg

All loads according to DIN 24094.

## DESCRIPTION

Chassis : high quality steel work, robot-welded.

Self-levelling lifting arm, especially beneficial for pallet fork operation.

Comfortable driver's cab with four-point suspension and reduced noise level.

Excellent manoeuvrability and precise operation.

## FILLING CAPACITIES

Fuel tank 210 l.

# AS 200

## STANDARD EQUIPMENT

Comfortable ROPS-cabin. Tinted glass, front and rear wind-screen wipers and washers, 1 inner and 2 outer rear-view mirrors, tinted sunroof, adjustable steering column, joystick and lever for auxiliary hydraulics.

Adjustable driver's seat with safety belt and hydraulic weight compensation.

Sun-visor, heating/ventilation system with outer air filter, cab lighting, storage compartments.

Well organized module cockpit, all indicators and warning lamps labelled (symbols).

12 V socket, 2 roof-mounted (front) headlights, 2 working lights mounted on loader arm, 2 roof-mounted (rear) working lights, indicator-, brake- and rear-lights.

Hydraulic quick-change device, tow-hook at the rear.

## OPTIONAL EQUIPMENT

30 km/h-version, tyres 20.5 R 25, flashing beacon, acoustic reversing alarm, FOPS-roof, bucket protector (road travel), travel load suspension, biodegradable hydraulic oil, radio, lift arm with security, low pressure return line.

Extensive range of attachments such as pallet forks, lift hook, grab, hydraulic breaker, etc. (see sep. list).

## NOISE LEVEL

Sound level in cabin (dynam.)	79 dB (A)
Sound level outside (dynam.)	104 dB (A)

## WEIGHT

Basic unit with quick-change device and 2 m <sup>3</sup> standard bucket with teeth	13750 kg
Axle load, front	5470 kg
Axle load, rear	8380 kg

Technical data are subject to modifications.

## DIAGRAMS

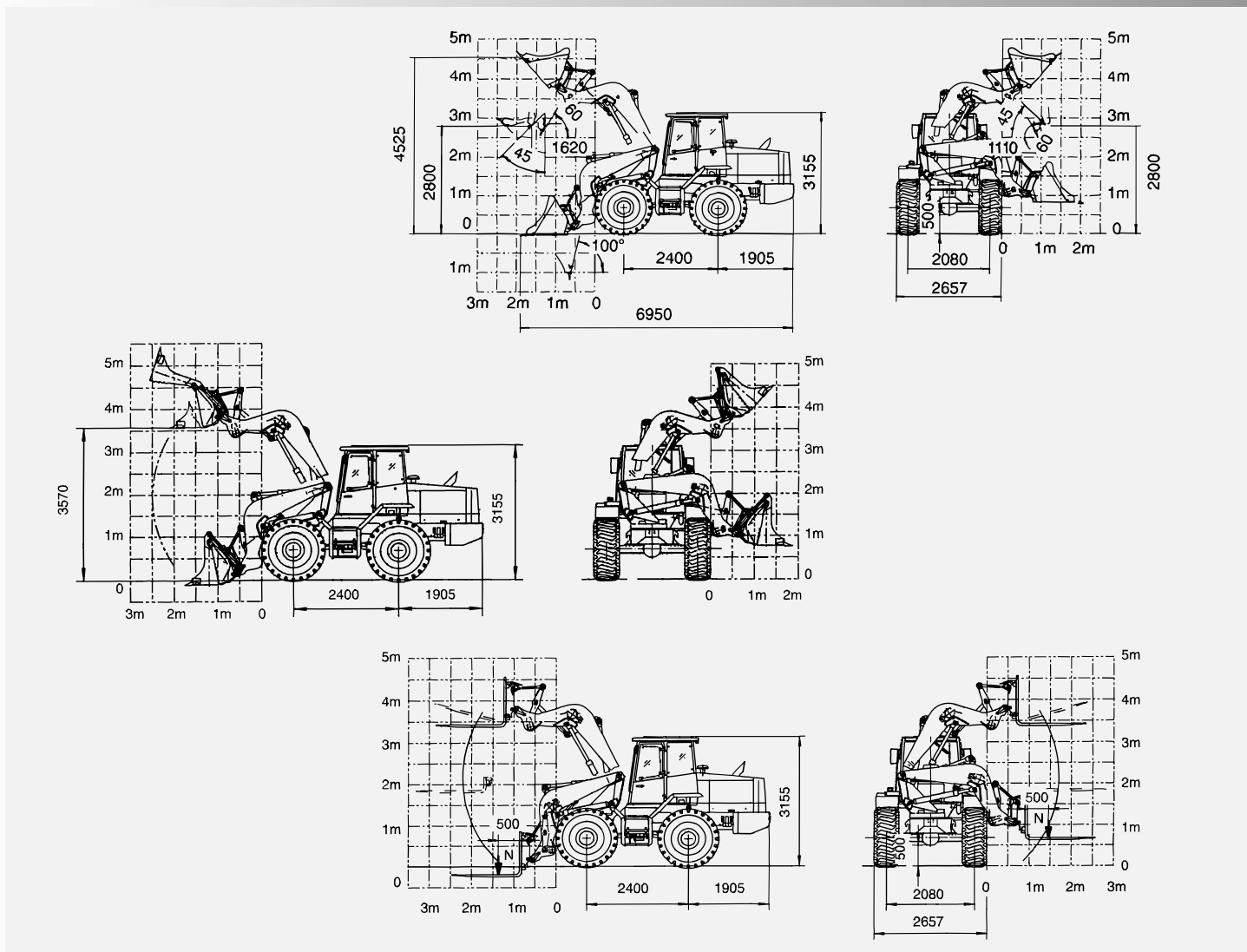

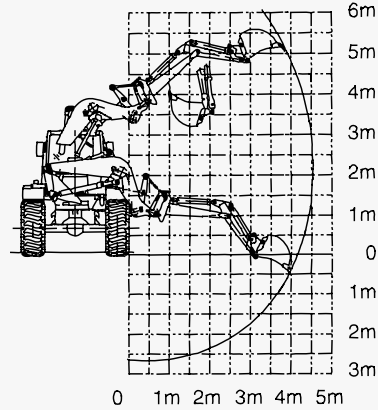
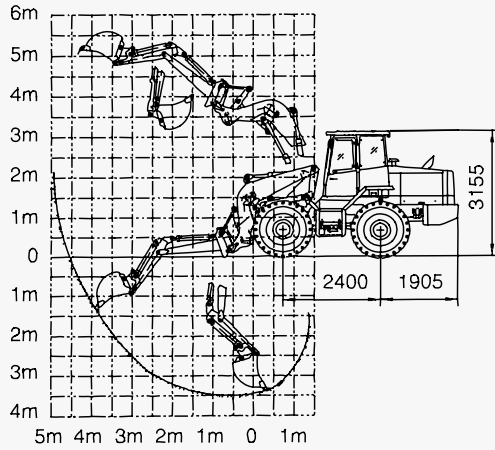
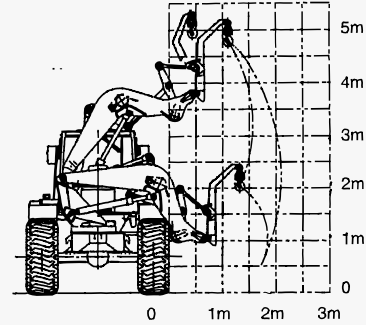
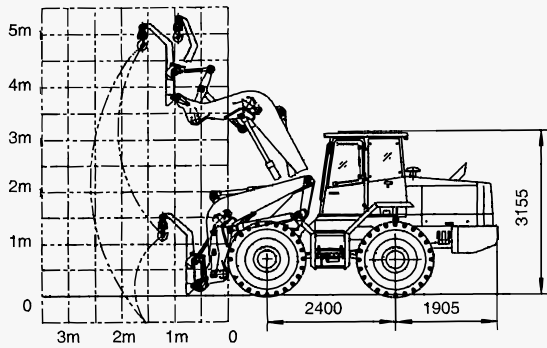

## ATTACHMENTS

- Buckets
- Multipurpose Buckets
- Grabs
- Forks and Grapple
- Lift Hook
- Sweeper
- Hydraulic Breaker
- Pallet Forks
- Ripper
- Universal Clamp
- etc.

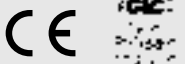
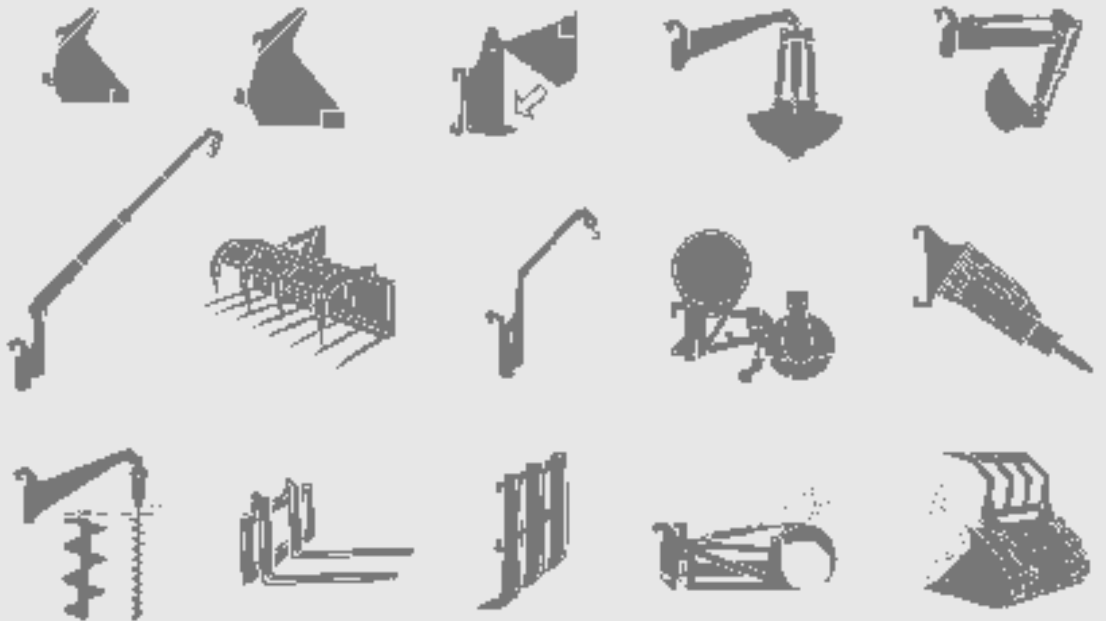

The power of imagination

B.P. 249 - 44158 ANCENIS CEDEX FRANCE

TEL : 33 2 40 09 10 11

EXPORT DEPARTMENT FAX : 33 2 40 09 10 97

www.manitou.fr