

# AL 70 E

- Buckets : 550 to 1000 litres
- Engine power : 50 HP
- Hydrostatic transmission
- Articulation without greasing points
- New "Z" bar linkage
- Hydraulic attachment quick coupling-device
- Self-stabilizing system of articulation
- Hydraulically-assisted joystick

*Articulated chassis*



**MANITOU** LOADER

# MANI LOADER

## ENGINE

Oil/air-cooled DEUTZ Diesel Engine,  
4 cylinders, 4-stroke, direct injection

Type	F 4L	1011F
Power at 2,300 rpm according to ISO 9249	36,5	kW (50 HP)
Max. torque at 1,800 rpm according to	155	Nm
Fuel consumption at max. torque	220	g/kWh
	161	g/HPh
Air filter aspiration 2 levels (safety cartridge)		
Electrics:		
Voltage	12	V
Battery	88	Ah
Alternator output	860 W	60 AT
Starter	(3HP)	2.2 kW

## TRANSMISSION

Load-adjusting hydrostatic transmission with two gears giving maximum pushing force, switchable while under load - 4-wheel drive.  
Multifunction joystick and forward/reverse lever.

Axles : planetary axles  
Steering and oscillation : by articulated chassis  
Differential : limited slip differential in front and rear axles

Limited slip differential front and rear : 45% / 45%

Tyres : standard 335/80 R18  
Option 405/70 R18

Travel speed : 0-20 km/h  
Working speed : 0-7 km/h

Gradeability : 60 %  
Ground clearance at differential : 295 mm  
Ground clearance centre of vehicle : 420 mm

## DESIGN

**Chassis :** - articulated chassis in high-quality steel, welded, "Z" bar linkage : 100% parallel lift, specially optimised for the use of forks. Automatic return of the bucket to working position.

- Self-stabilizing system of articulation

- Articulation without greasing points (arm / articulation / transmission)

**Cab :** comfortable, fully suspended (mounted on 4 silent-blocs)

Noise level cab (dynam.) : 81 dB (AT)  
Noise level ext. max. (dynam.) : 99 dB (AT)

## STEERING

Oscillation angle 2 x 11°  
Articulation angle 2 x 40°  
Turning radius at the rear R4 = 3900 mm

## BRAKING SYSTEM

Service brake : multi-disc brake (oil immersed), operated hydraulically on the front axle and acting on all 4 wheels by the transmission

"Inching" function on service brake

Parking brake : hydraulic brake acting by spring-loaded accumulator on the front axle and by the transmission on all 4 wheels.

## HYDRAULICS

Single hydraulic system :  
Lifting / lowering / crowding / dumping / attachments controls, as well as steering (via priority valve) by hydraulic 3-way distributor with pressure control on outlets.

Hydraulically-assisted steering and joystick control / proportional controls.

Flow and pressure max. at 2,300 rpm : 61 l /min & 190 bar

Cylinders : 2 lift cylinders ø 80 mm  
1 tilt cylinder ø 100 mm

Cycle times according to DIN ISO 7131 :

Lifting (with load)	5,8 s
Lowering (without load)	3,8 s
Dumping 90°	1,2 s
Crowding 45°	1,0 s

## FILLING CAPACITIES

Fuel tank 70 l  
Hydraulic system including tank 100 l

## PERFORMANCE

Digging depth (standard bucket) 135 mm

Bucket angle  
Crowding 49°  
Dumping 49°  
Dumping max. 93°

AL 70 E

# AL70 E

## DIAGRAMS

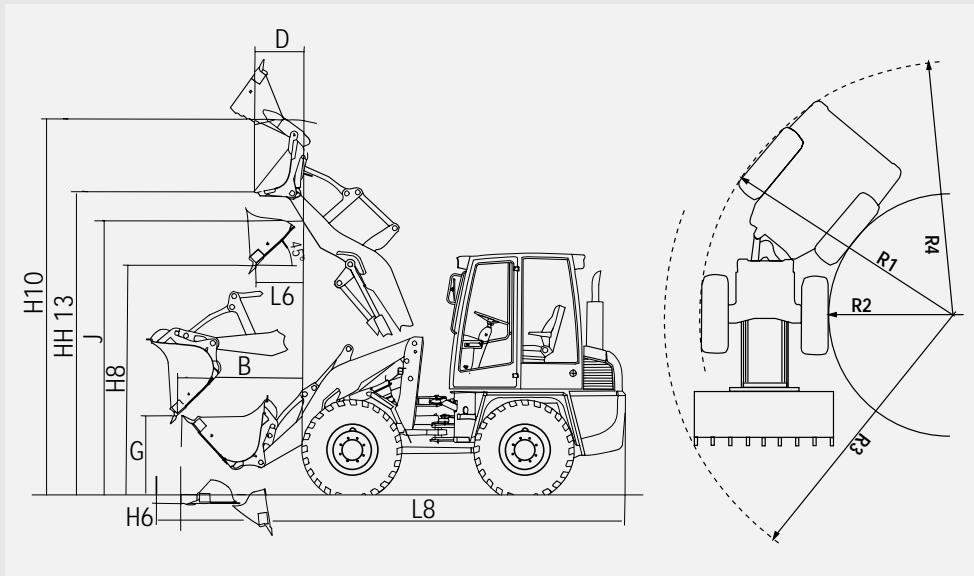

	Standard	Multipurpose
Volume :	0,7 m <sup>3</sup>	0,55 m <sup>3</sup>
B	1285	1380
G	880	790
H6	135	175
H8	2575	2490
H10	4030	4055
J	2960	2960
L6	530	535
L8	5055	5040
D (open)	-	565
HH 13 (open)	-	3325
R1	3800	
R2	1900	
R3	3990	
R4	3900	

DIMENSIONS OF THE MACHINE	Dimensions in mm
	AL70 E
Height	2665
Width over tyres	1775
Width over standard bucket	1800
Wheelbase	1950
Length with standard bucket	5055

## TECHNICAL CHARACTERISTICS

CHARACTERISTICS WITH PNEUS 335/80 R18 TYRES		STANDARD BUCKET		MULTIPURPOSE BUCKET	LIGHT-DUTY BUCKET
Volume according to DIN ISO 7546	m <sup>3</sup>	0,7	0,65	0,55	1,0
Density according to ISO 8313	t/m <sup>3</sup>	1,7	1,75	1,8	1,1
Tipping load at max. reach in line according to ISO 8313	kg	2800	2800	2660	2700
Tipping load at max. reach, articulated, acc. to ISO 8313	kg	2240	2240	2100	2140
Lifting force according to ISO 8313	daN	3400	3400	3400	3400
Tractive force	kN	35,3	35,3	35,3	35,3
Breakout force according to ISO 8313	daN	4230	4230	4425	3450
Width of the bucket	mm	1800	1800	1870	2000
Turning radius with bucket	mm	3990	3990	4020	4100
Dumping height under bucket	mm	2575	2575	2490	2550
Reach at max. height	mm	530	530	535	550
Maximum reach	mm	1285	1285	1380	1340
Permitted load - front axle	kg	3500	3500	3500	3500
Permitted load - rear axle	kg	4000	4000	4000	4000
Crowding angle	°	49	49	49	49
Dumping angle at max. height	°	49	49	46	49
Operating weight with bucket	kg	4640	4630	4830	4680

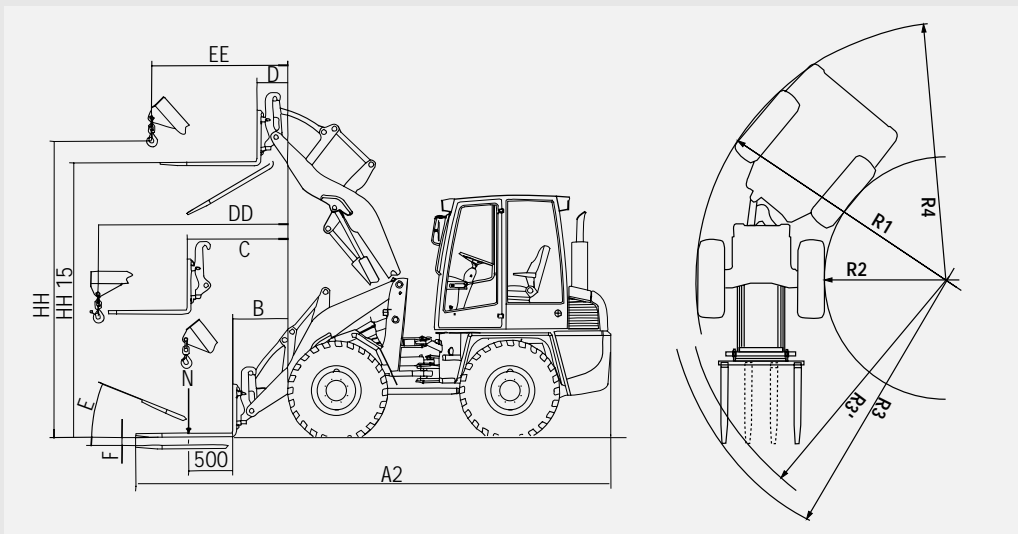

	AL 70 E
A2	5515
B	710
C	1200
D	380
E	15°
F	75
HH15	3125
Lifting jib	
DD	2210
EE	1050
HH	3950
R1	3800
R2	1900
R3	4050
R4	3900

		AL 70 E
Payload on pallet forks according to ISO 8313 (in front position)	Level ground	1920 kg
	Uneven ground	1440 kg
Payload on pallet forks according to ISO 8313 (in articulated position)	Level ground	1575 kg
	Uneven ground	1180 kg
Payload on pallet forks according to ISO 8313 (in front position)*	Level ground	2380 kg
	Uneven ground	1780 kg
Payload on pallet forks according to ISO 8313 (in articulated position)*	Level ground	2000 kg
	Uneven ground	1500 kg

\* forks 150mm from ground level

### STANDARD EQUIPMENT

Comfortable 2-door ROPS cab - Tinted windows - Windscreen wiper / washer front and rear - Sun visor - Sun roof - Heated rear window - Cut-off switch in the cab - Joystick and lever for hydraulic attachments - Modular dashboard - Warning display lights - Safety belt - Storage rack - Interior light - 3-position heater/air conditioning (exterior air filter) - Mug holder - Radio installation facility - 1 interior rear mirror + 2 exterior - 12V electrical socket in the cab - 2 driving lights mounted at the front and 2 working lights mounted at the rear of the cab - Rotating beacon - Reversing lights, indicators and stop lights - Reverse alarm - Tool kit - Auxiliary hydraulic system - Bucket position indicator - Hydraulic attachment locking system

### LIST OF OPTIONS

405/70 R18 Tyres - 385/55 R18 Tyres - 2 working lights on the arm - Radio - Loader arm suspension - Anti-theft system (transponder or digicode) - Direct return line - Towing facility - Permanent power to the attachments circuit for road sweeper - Safety valves on lifting and crowding cylinders.

### ATTACHMENTS

- Buckets
- Multipurpose bucket
- Grab fork
- Lifting jib
- Road sweeper
- Hydraulic hammer
- Forks
- etc..

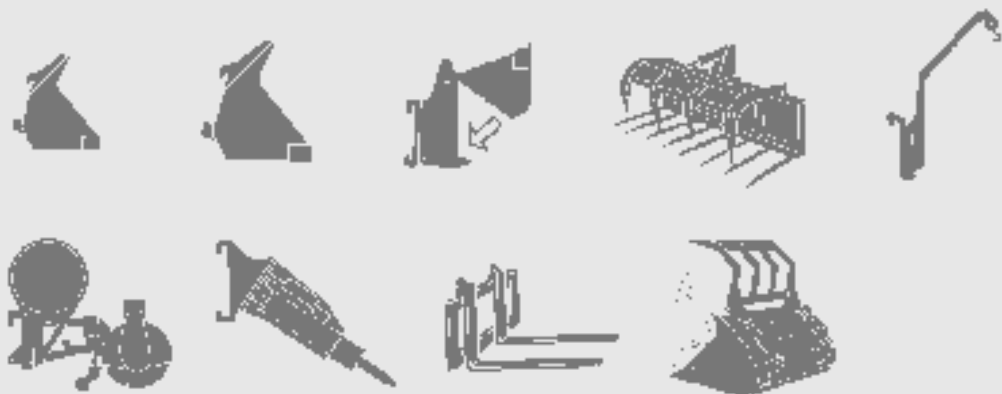

This publication in no way constitutes an offer and the company reserves the right to alter specification without prior notice. The MANITOU models presented in this brochure can be supplied complete with optional equipment attachments



MANITOU B.F. S.A.  
B.P. 249 - 44158 ANCENIS CEDEX - FRANCE  
TEL : 33 2 40 09 10 11  
EXPORT DEPARTMENT FAX : 33 2 40 09 10 97  
www.manitou.fr