

# MANILEC

■ **ES 8 series**

**Electric stacker**



 **MANITOU**

# ES 8 series : Electric stacker 1600 kg - 2000 kg

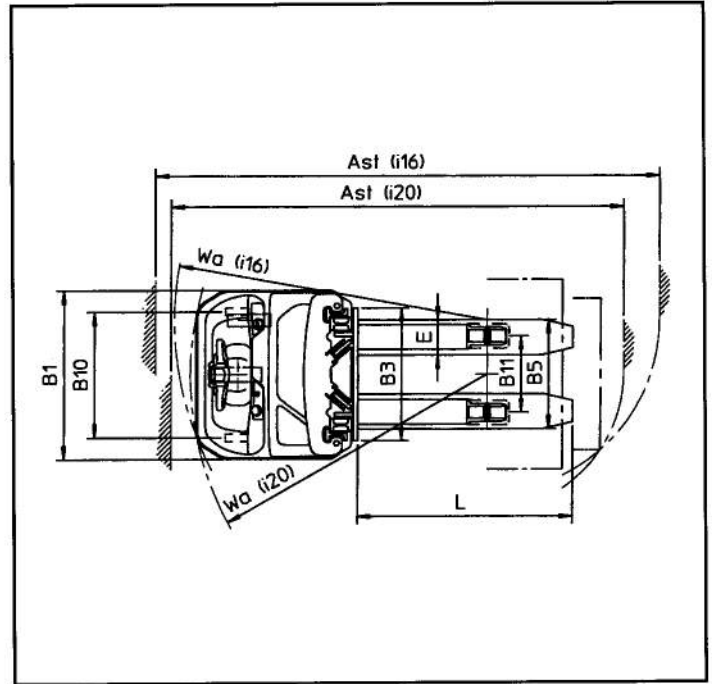
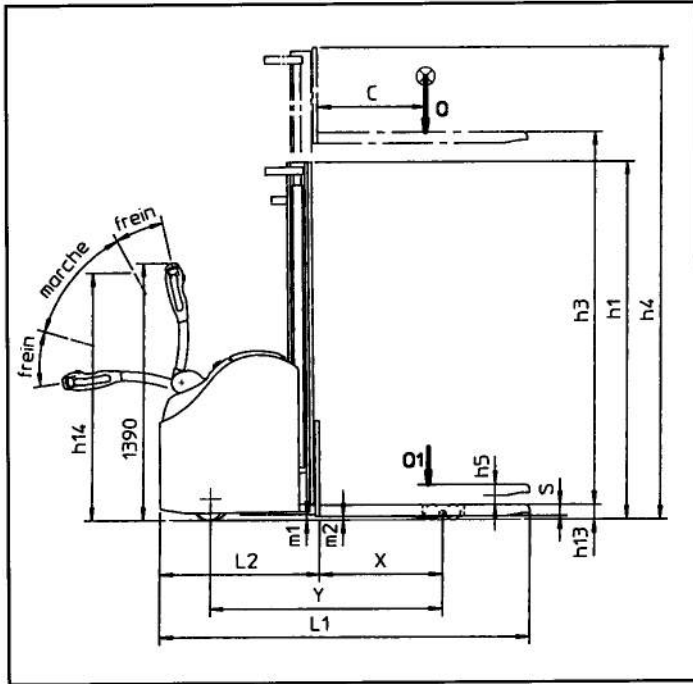

Mast ref. for ES 816 FR & ES 820 FR		Height of raised fork		Height of stacker with mast	
dimensions in mm		maxi h3+h13	free h2+h13	lowered h1	raised h4
Simplex	S 15	1505	1505	1940	1960
	S 17	1755	1755	2190	2210
Duplex	D 29	2935	-	1940	3395
	D 34	3835	-	2190	3895
	D 38	3835	-	2390	4295
Free lift duplex	DLL 29	2930	1505	1940	3390
	DLL 34	3430	1755	2190	3890
Triplex	T 42	4255	-	1990	4795
	T 48	4855	-	2190	5395
	T 54	5455	-	2390	5995

\* Please, add 5 mm to "h3 + h13" and "h2 + h13" for ES 820 FR model

Mast ref. for ES 816 LI & ES 820 LI		Height of raised fork		Height of stacker with mast	
dimensions in mm		maxi h3+h13	free h2+h13	lowered h1	raised h4
Simplex	S 15	1510*	1510*	1955*	1965*
	S 17	1760*	1760*	2205*	2215*
Duplex	D 29	2940*	-	1955*	3400*
	D 34	3440*	-	2205*	3900*
	D 38	3840	-	2405	4300
Free lift duplex	DLL 29	2935*	1510*	1955*	3395*
	DLL 34	3435*	1760*	2205*	3895*
Triplex	T 42	4260	-	2005	4800
	T 48	4860	-	2205	5400
	T 54	5460	-	2405	6000

\* Please, add 110 mm for initial lift high

# ES 8 series : Electric stacker 1600 kg - 2000 kg

				MANITOU		
				ES 816 FR-LI*	ES 820 FR-LI*	
<b>Designation</b>	1.1	Manufacturer				
	1.2	Model type				
	1.3	Powered by: battery, diesel, petrol, LPG, mains electricity			Battery	Battery
	1.4	Driving method: manual, walk-along, upright, seated, preparation			Pedestrian	Pedestrian
	1.5	Nominal capacity	Q	t	1,6	2
	1.6	Height to centre of gravity	C	mm	600	600
	1.8	Distance from fork face to track wheels (in raised pos'n)	x	mm	675 - 851/809*	670 - 846/804*
	1.9	Wheelbase (drive axle to track wheels), top/bottom position	y	mm	1277 - 1529/1487*	1334 - 1502/1544*
	<b>Weights</b>	2.1	Weight in working order		kg	1401
2.2		Axle loading when load (front/rear)		kg	1093/2162	1147/2270
2.3		Axle loading when unload (front/rear)		kg	1024/391	1075/411
<b>Wheels</b>	3.1	Tyres (front/rear)			Polyurethane	Polyurethane
	3.2	Front wheel dimensions (dia x width)		mm	230x75	250x90
	3.3	Rear wheel dimensions (dia x width)		mm	82x68	82x68
	3.4	Outrigger dimensions		mm	140x60	120x50
	3.5	Number of wheels front/rear (x = drive wheel)			1x1/4	1x2/4
	3.6	Track centres, front	b10	mm	604	664
	3.7	Track centres, rear	b11	mm	403 - 675*	403 - 375*
<b>Dimensions</b>	4.2	Height with mast lowered (D29)	h1	mm	1940 - 1955*	1940 - 1955*
	4.3	Normal free lift (D29)	h2	mm	-	-
	4.4	Standard lift (D29)	h3	mm	2850	2845 - 2850*
	4.5	Height with mast raised (D29)	h4	mm	3395 - 3400*	3395 - 3400*
	4.6	Initial lift	h5	mm	0 - 110*	0 - 110*
	4.9	Handle height in driving position	h14	mm	-	-
	4.15	Fork height when lowered	h13	mm	85 ± $\frac{5}{8}$ - 90 ± $\frac{5}{8}$	90 ± $\frac{5}{8}$
	4.19	Overall length	l1	mm	2033 - 2147*	2038 - 2152*
	4.20	Length to front face of forks	l2	mm	883 - 957*	888 - 962*
	4.21	Overall width	b1	mm	890	890
	4.22	Fork dimensions (thick x wide x long)	s/e/l	mm	60x185x1150 - 60x200x1190*	70x185x1150 - 70x200x1190*
	4.24	Width of fork carriage	b3	mm	700	700
	4.25	Fork pitch	b5	mm	575	575
	4.26	Width between carrying arms (min./max.)	b4	mm	-	-
	4.31	Ground clearance under mast	m1	mm	35 - 20*	30 - 20*
	4.32	Ground clearance at centre of wheelbase	m2	mm	25 - 20*	20
	4.33	Aisle width with 1000x1200 pallet widthwise (l6xb12)	AST	mm	2660 - 2735*	2335 - 2410*
4.34	Aisle width with 800x1200 pallet lengthwise (b12xl6)	AST	mm	2690 - 2765*	2415 - 2490*	
4.35	Turning radius (top/bottom position)	Wa	mm	1675 - 1750*	1590 - 1665*	
<b>Performance</b>	5.1	Travel speed, load/unload		km/h	5,5/6	5/6
	5.2	Lifting speed, load/unload		m/s	0,12/0,21	0,10/0,21
	5.3	Lowering speed, load/unload		m/s	0,32/0,24	0,35/0,24
	5.8	Maximum slope laden/unladen (S2 5 min.)		%	7/10	6/10
	5.10	Drive brake			Electromagnetic	Electromagnetic
	5.11	Parking brake			Handle release	Handle release
<b>Drive unit</b>	6.1	Drive motor power (S2 60 min)		kW	1,2	1,25
	6.2	Lift motor power (S3 10%)		kW	4,5	4,5
	6.3	Battery type as per standard DIN 43531/35/36,A,B,C			Traction	Traction
	6.4	Battery voltage and capacity		V/Ah	24/270-360 - 24/270-315*	24/270-360 - 24/270-315*
	6.5	Battery weight ( $\pm$ 5%)		kg	250-370 - 250-320*	250-370 - 250-320*
<b>Misc</b>	8.1	Speed control			Sepex Mosfet Variator	
	8.4	Average sound level at driver's ears (translation)		dB (A)	65	65

\* Dimensions for LI (initial lift) model

**Manitou, leader mondial de la manutention tout terrain**  
**Manitou, world wide leader of rough terrain handling equipment**  
**Manitou, Der Weltmarktführer für geländegängige Flurförderstapler**  
**Manitou, Líder mundial de la manutención todo terreno**



**MANISCOPIC**

**MANITOU**

**MANIACCESS**

*Twiso*

**MANITRANSIT**

**MANIHOE**

**MANILOADER**

**MANILEC**



Un réseau de spécialistes  
à votre service

A network of skilled  
professionals at  
your service

Una red de especialistas  
a su servicio

Ein dichtes Netz von  
Spezialisten steht zu  
Ihrer verfügung



**MLM**

Z.I., 5 avenue du Vert-Galant 95310 SAINT OUVEN-L'AUMONE FRANCE  
Tél. : +33 (0) 1.34.32.65.06 or 08 Fax : +33 (0) 1.34.32.65.10

 **MANITOU**